

SHURflo®

RV FRESH WATER PUMP Installation and Operation Manual

Shurflo's RV Fresh Water Pumps for drinking water were developed to deliver smooth, consistent flow at all ranges of operation, while drawing low current. The balanced diaphragm design incorporates precision ball bearings for long life. Each motor is equipped with an integral thermal breaker and all units are CE approved. RV fresh water pumps are enclosed to prevent incidental moisture from entering; however, they are not intended for environments where splashed water is present. When installed correctly, RV Fresh Water Pumps provide years of quiet operation.

General Information

Shurflo water pumps meet the essential health and safety requirements and are in conformity with the EU EMC directive 89/336/FEC as specified in EN 55014 (1993). Shurflo realizes that in many instances our pump is being installed as a replacement pump within an existing system. The following guidelines should be considered to achieve optimum pump operation.

Mounting

The pump can be at the same level or below the water tank. It may be positioned above the water tank if needed, as it is capable of a 6 ft. (1.8 m) vertical prime. Horizontal inlet tubing will allow priming to 30 ft. (9 m).

Consider a dry location that allows easy access if maintenance is required. The pump should not be located in an area of less than one cubic foot (0.03 m) unless adequate ventilation is provided. Excessive heat may trigger the integral thermal breaker and interrupt operation. When the temperature drops, the breaker will auto-

matically reset and start the operation. The pump may be mounted in any position. If mounting the pump vertically, the pump head should be in the down position so that in the unlikely event of a leak, water will not enter the motor.

Use No.8 stainless steel hardware to fasten the pump. Choose a solid surface (thick plywood) that will not amplify pump operation. The mounting feet are intended to isolate the pump from the mounting surface; over tightening, flattening, or use of oversized screws will reduce the ability to isolate vibration/noise.

Electrical

The pump should be on a dedicated (individual) circuit protected by the specified fuse as indicated on the motor label.

A switch rated at or above 15 amps is recommended, and must interrupt current flow on the positive (+ red) lead.

The pump must be grounded to an earth (battery). The earth wire must be the same size (gauge/mm²) as the positive wire.

Wire size (gauge/mm²) is based on the distance from the power source to the pump. The minimum recommended size wire is No.14 gauge (2.5mm²). Lengths of 20-50ft. (6-15m) use No.12 gauge (4mm).

The total current draw on the circuit must not exceed 15 amps. If the pump is used in conjunction with other components, overload current protection (fuse or circuit breaker) and wire size must be for the total amp requirement of all devices on the circuit.

Plumbing

Shurflo recommends at least 1 ft. (0.3m) of 1/2" (13mm) I.D. flexible high pressure tubing to both ports. Ideally the pump's ports/strainer *should not* be connected to plastic or rigid pipe. The pump's normal oscillation may transmit through rigid plumbing causing noise, and possibly loosen or crack components.

Installation of a 50 mesh strainer is recommended to prevent foreign debris from entering the pump.

The Shurflo In-Line Strainer (1/B and 2/B) has a twist-lock feature allowing simple cleaning when plumbed with flexible tubing.

Shurflo swivel barb fittings provide easy removal if maintenance or access is required. The fittings are designed with a "taper-seal", creating water tight connection when *hand tightened*. Always secure barb tubing connections with properly

sized stainless steel clamps to prevent leaks. *Never* use Teflon tape or sealing compounds on threads. Sealer may enter the pump causing a failure. *Failure due to foreign debris is not covered under warranty.*

Rapid cycling may be caused by excessive back pressure created by one or more of the following within a plumbing system:

- Water filters and purifiers not on separate feed lines.
- Flow restrictors in taps and shower heads.
- Small I.D. lines. Pipe/tubing should be at least 1/2" (13mm) I.D. for main lines.
- Restrictive fittings and connections (elbows, "T's", feeder lines to taps, etc.)

Switch Shut-Off

Restrictions in a plumbing system may cause the pump to rapid cycle (ON/OFF within 2 sec.) during low flow demands. Cycling should be minimized to prevent pulsating flow, and to achieve maximum pump life.

To determine if adjustment is necessary, turn tap on to lower than average flow of water. The pump should cycle, but its "OFF time" must be 2 sec. or longer. If the

cycling is correct, leave well enough alone. If the pump is cycling rapidly increase the setting by turning the screw clockwise (1 1/2 turn MAX.) until the pump operates for 1 sec. with at least 2 sec. "OFF time". If cycling cannot be minimized consider removing plumbing restrictions or simply install a Shurflo Accumulator.

Sanitizing

Fresh water systems require periodic maintenance to deliver a consistent flow of fresh water. Depending on the use and the environment the system is subject to, sanitizing is recommended prior to storing and before using the water system after a period of storage. Systems with new components, or ones that have been subjected to contamination, should also be disinfected as follows:

1. Use one of the following methods to determine the amount of common household bleach needed to sanitize the tank.

A) Multiply "gallons (UK) or tank capacity" by 0.156; the result is ounces of bleach needed to sanitize the tank.

B) Multiply "litres of tank capacity" by 1; the result is the millilitres of bleach needed to sanitize the tank.

2. Mix into solution the proper amount of bleach within a container of water.
3. Pour the solution (water/bleach) into the tank and fill the tank with fresh water.
4. Open all taps (HOT & COLD) allowing the water to run until the distinct odour of chlorine is detected.
5. The standard solution must have four (4) hours of contact time to disinfect completely. Doubling the solution concentration allows for contact time of (1) hour.
6. When the contact time is completed, drain the tank. Refill with fresh water and purge the plumbing of all sanitizing solution.

NOTE: The sanitizing procedure outlined above is in conformance with the approved procedures of the U.S. Public Health Service.

Winterizing

If water is allowed to freeze in the system, serious damage to the plumbing and the pump may occur. Failures of this type will void the warranty. The best guarantee against damage is to completely drain the water system. However, **non-toxic anti-freeze for fresh water**, available at local RV centres, may be used.

CAUTION: Do not use Automotive Antifreeze to winterize drinking water systems. Such solutions are highly toxic. Ingestion may cause serious injury or death. To properly drain the system perform the following:

1. Drain the water tank. If the tank doesn't have a drain valve open all taps allowing the pump to operate (15 min. ON, 15 min. OFF) until the tank is empty.
2. Open all the taps (including the lowest valve or drain in the plumbing) and allow the pump to purge the water from the plumbing, then turn the pump OFF.
3. Using a pan to catch the remaining water, remove the plumbing at the pump's inlet/outlet ports. Turn the pump ON, allowing it to operate until the water is expelled. Turn OFF power to the pump once the plumbing is emptied. **Do not** reconnect pump plumbing. Make a note at tank filler as a reminder: "Plumbing is Disconnected".
4. All taps must be left open to guard against any damage.

Troubleshooting

Vibration induced by road conditions or transporting can cause plumbing or pump hardware to loosen. Check for system components that are loose. Many symptoms can be resolved by simply tightening the hardware. Check the following items along with other particulars of your system.

PUMP WILL NOT START/BLOWS CIRCUIT:

- ✓ Electrical connections, fuse or breaker, main switch, and ground connection.
- ✓ Is the motor hot? Thermal breaker may have triggered; it will reset when cool.
- ✓ Is voltage present at the switch? Bypass the pressure switch. Does the pump operate?
- ✓ Charging System for correct voltage ($\pm 10\%$) and good ground.
- ✓ For an open or grounded circuit, or motor; or improperly sized wire.
- ✓ For seized or locked diaphragm assembly (water frozen?).

WILL NOT PRIME/SPUTTERS:

- (No discharge/motor runs)
- ✓ Is the strainer clogged with debris?
 - ✓ Is there water in the tank, or has air collected in the hot water heater?
 - ✓ Is the inlet tubing/plumbing sucking in air at plumbing connections (vacuum leak)?
 - ✓ Is the inlet/outlet plumbing severely restricted or kinked?
 - ✓ Proper voltage with the pump operating ($\pm 10\%$).
 - ✓ For debris in pump inlet/outlet valves or swollen/dry valves.
 - ✓ Pump housing for cracks or loose drive assembly screws.

PUMP WILL NOT SHUT-OFF/RUNS WHEN TAP IS CLOSED:

- ✓ Output side (pressure) plumbing for leaks, and inspect for leaky valves or toilet.
- ✓ For air trapped in outlet side (water heater) or pump head.
- ✓ For correct voltage to pump ($\pm 10\%$).
- ✓ For loose drive assembly or pump head screws

- ✓ Are the valves or internal check valve held open by debris or is rubber swollen?
- ✓ Pressure switch operation/adjustment incorrect, refer to shut-off adjustment for switch.

NOISY OR ROUGH OPERATION:

- ✓ For plumbing which may have vibrated loose.
- ✓ Is the pump plumbed with rigid pipe causing noise to transmit?
- ✓ Does the mounting surface multiply noise (flexible)?
- ✓ For mounting feet that are loose or are compressed too tight.
- ✓ For loose pump head to motor screws. (3 long screws)
- ✓ The motor with pump head removed. Is noise from motor or pump head?

RAPID CYCLING:

- ✓ Pressure switch shut-off adjustment.
- ✓ Water filter/purifier should be on separate feed line.
- ✓ For restrictive plumbing, flow restrictors in taps/shower heads.

LEAKS FROM PUMP HEAD OR SWITCH:

- ✓ For loose screws at switch or pump head.
- ✓ Switch diaphragm ruptured or pinched.
- ✓ For punctured diaphragm if water is present in the drive assembly.

Service Kits

(See Fig.3)

To ensure the correct service kit, order by the complete model number, date of manufacture and name plate data. Part kits come with complete repair instructions.

- ① Switch/Check valve and Upper Housing Kit (replaces all previous switch designs)
- ② Switch/Check Valve plate assembly
- ③ Diaphragm/Drive assembly
- ④ Motor
- ⑤ Complete Pump Head assembly (includes part nos. 1, 2 and 3) (Replaces all previous switch designs)

Limited Warranty

Shurflo warrants its RV Duty Fresh Water Pumps to be free of defects in workmanship and materials (under normal use) for two years beginning with the purchase date of the unit.

This warranty does not extend to any Shurflo products which have been misapplied, improperly installed or altered outside the Shurflo factory.

Accessories & Fittings

Shurflo's warrants its accessories and fittings to be free of defects in workmanship and materials (under normal use) for one year beginning with the purchase date of the accessory or fitting.

This warranty does not extend to any Shurflo products which have been misapplied and/or improperly installed.

All Products

Shurflo is not responsible nor will it reimburse for labour necessary to remove and reinstall a pump and/or fittings and accessories if found defective.

Shurflo's obligation under this warranty policy is limited to the replacing or repairing (whichever it deems advisable) any such part which is returned to Shurflo's factory with transportation charges pre-paid and which, upon Shurflo's inspection is found defective under the terms of this warranty.

☆ KEY TO DRAWINGS (BACK PAGE)

Figure 1

- | | |
|--|--------------------------|
| 1/A Pump | 1/F Mains water supply |
| 1/B Twist-on strainer* | 1/G Shut-off/Drain valve |
| 1/C Accumulator* | 1/H Water tank |
| 1/D Pressure regulator (tap mounting model*) | 1/I Switch |
| 1/E (wall mounting model*) | 1/J Fuse |
| | 1/K Water heater |

Figure 2

- | | |
|----------------------------------|--------------------------------------|
| 2/B Twist-on strainer | 2/P Fresh water inlet |
| 2/L Screw | 2/Q Mount on solid surface |
| 2/N 12.5 mm High pressure tubing | 2/R Battery or earth |
| 2/M Stainless steel clamps (x2) | 2/S Swivel barb fittings* (supplied) |
| 2/O Fuse | 2/T Connector |

Figure 3

- 1 Upper Housing Switch
- 2 Valve Assembly
- 3 Drive Assembly
- 4 Motor
- 5 Pump Head

* = Shurflo optional accessories

Fig 1

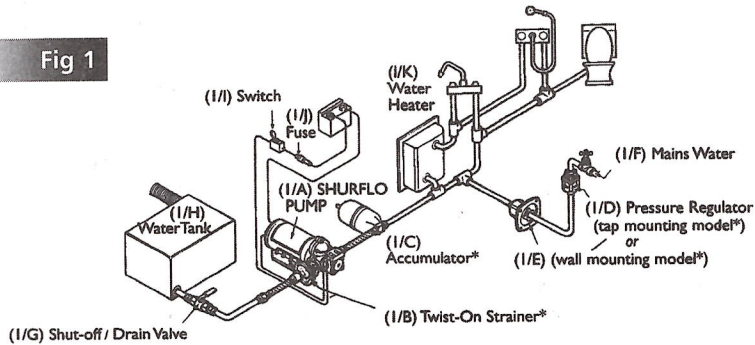

Typical fresh water system shown with optional* SHURflo accessories

Fig 2

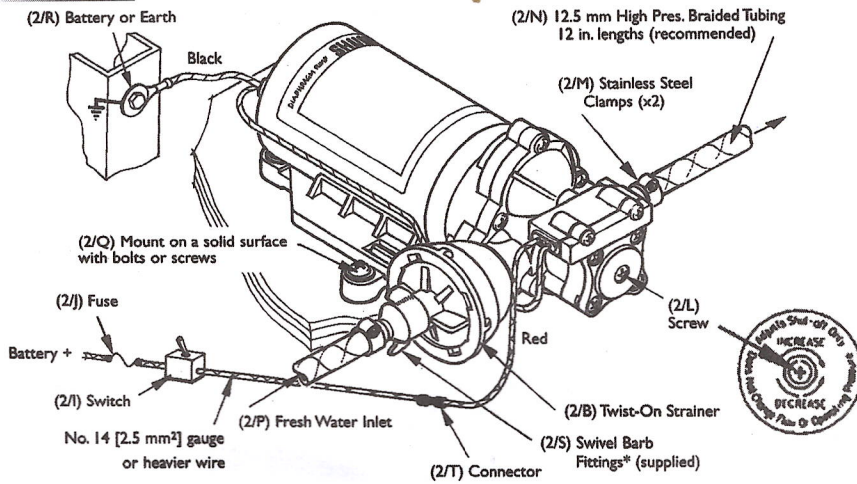
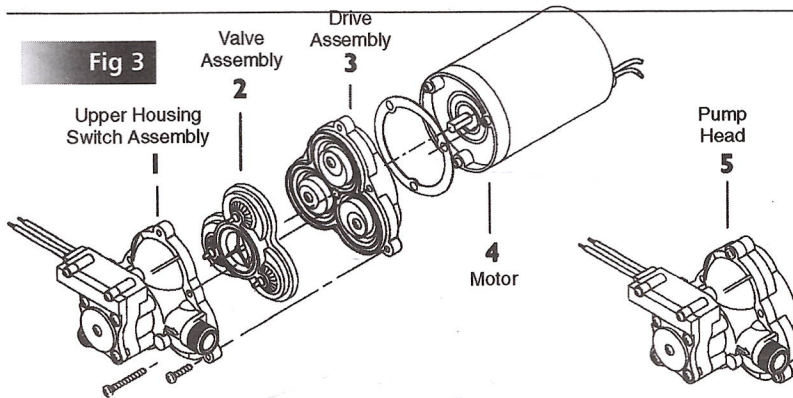

Fig 3



SHURflo, LLC Headquarters
 5900 Katella Avenue
 Cypress, California 90630
 Phone (562) 795-5200 • Toll Free (800) 854-3218
 Fax (562) 795-7564

SHURflo, LLC East
 52748 Park Six Court
 Elkhart, Indiana 46514-5427
 Phone (562) 795-5200 • Toll Free (800) 854-3218
 Fax (574) 264-2169

SHURflo Europe, Middle East, Africa
Pentair Water Belgium bvba,
 Industriepark Wolfstee, Toekomstlaan 30
 B-2200 Herentals, Belgium
 Phone +32-14-283500 • Fax +32-14-283505

© 2001 Printed in USA